

# Finsbury - Bare Shaft Pumps

## 250 Series



### Standard

160 Series bare shaft single stage centrifugal pumps are designed manufactured to ISO Standard 2858

Sl.	Model Number	Max. Shaft Power	Max. Speed RPM	Max. Head Mtr.	Max. Flow LPS
1	FPS-65 x 40-250	60.0Kw	3500	166.0	22.6
2	FPS-80 x 50-250	97.0Kw	3500	164.0	38.7
3	FPS-100 x 65-250	74.0Kw	3500	110.0	48.9
4	FPS-125x100-250	103.0Kw	3500	108.0	94.0
5	FPS-150x125-250	88.0Kw	3500	78.0	94.0

Maximum ambient temperature +60°C  
Maximum fluent temperature +80°C  
Maximum casing pressure 16 bar  
Fluid must be clean free from abrasive particles  
Wear rings - bronze wear rings can be fitted to impeller and casing

Standard MOC  
Casing-SG 500/7  
Impeller-SS316-Bronze  
Shaft-Stainless Steel 431 with water slinger  
Bearing-Fully Sealed heavy duty roller bearing

### INDRA HYDRO TECH PUMPS PVT LTD

No.85/M, Ground Floor, Industrial Suburb, 2nd Stage Gautham Nagar, Tumkur Road  
Yeshwanthpur, Bangalore 560 022, Karnataka, INDIA

Tel. : +91 80 4163 5638, Mobile: +91 94835 26899 / 80736 22800  
Email : sales@ihpumps.in, Web : www.ihpindia.in | www.ihpumps.in

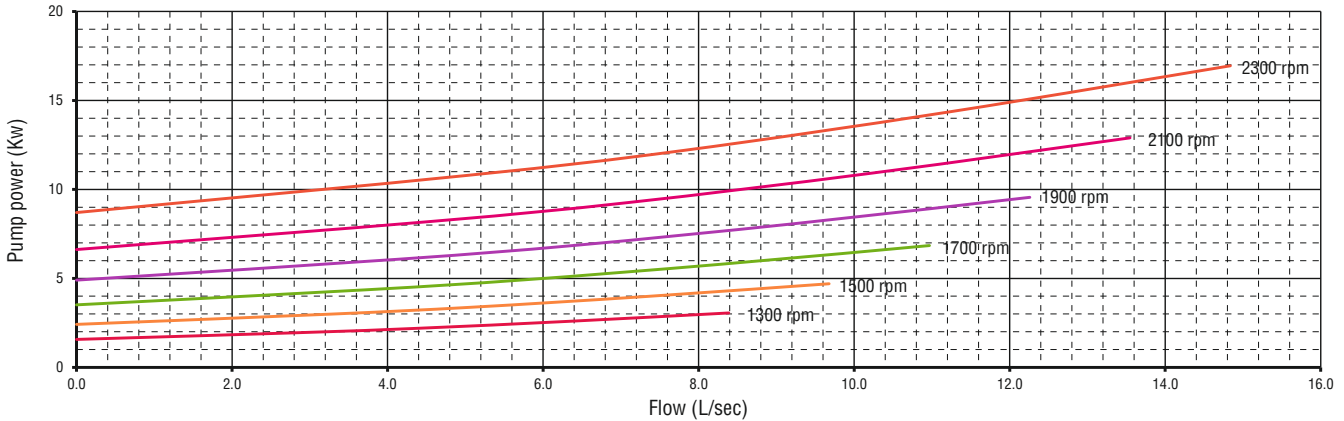
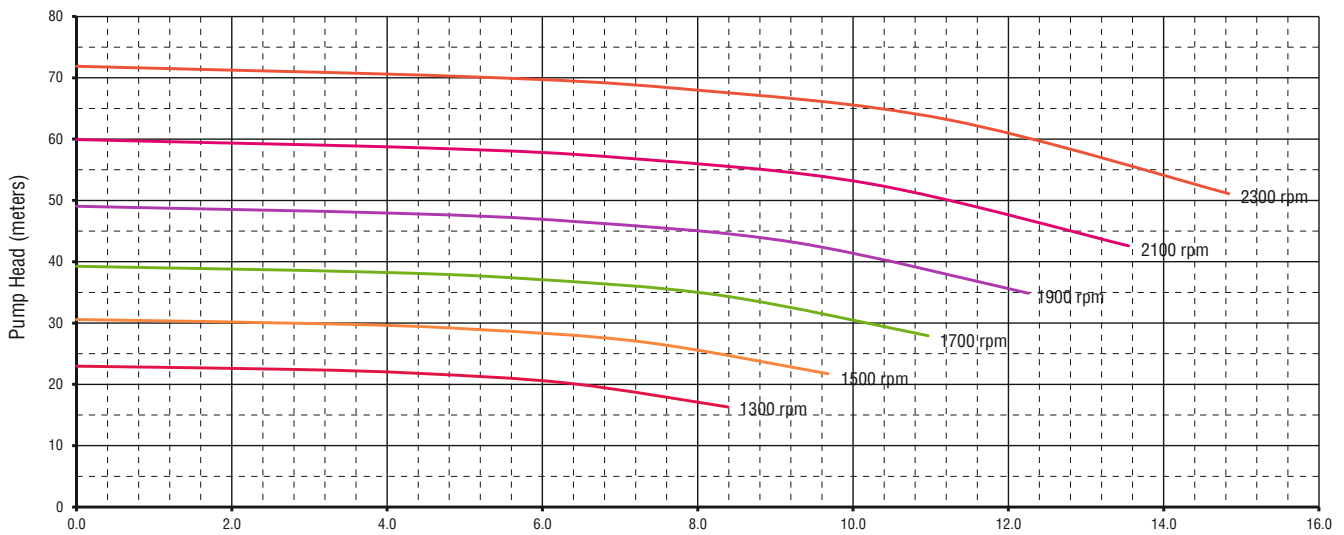
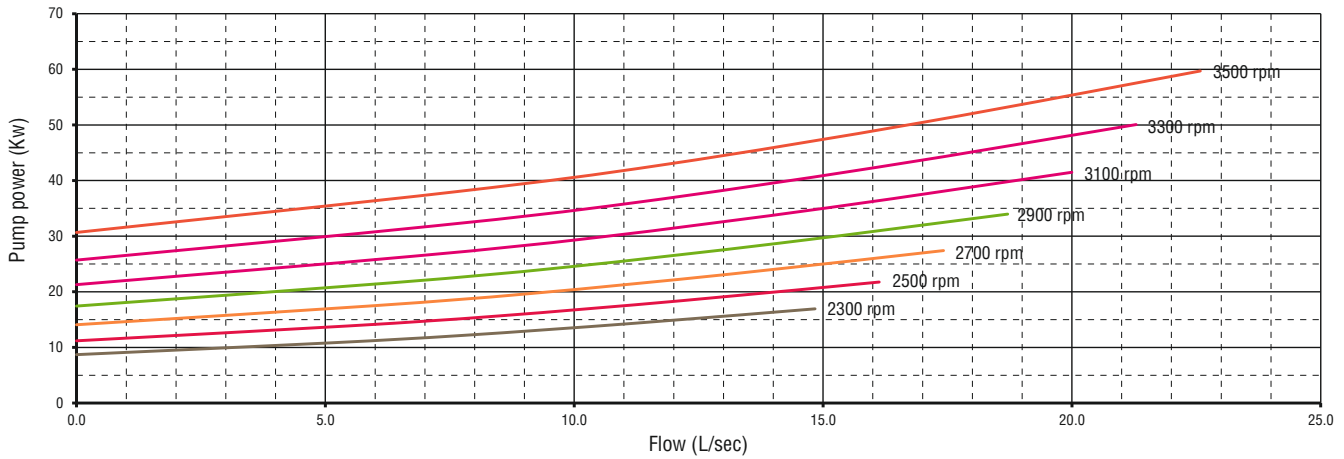
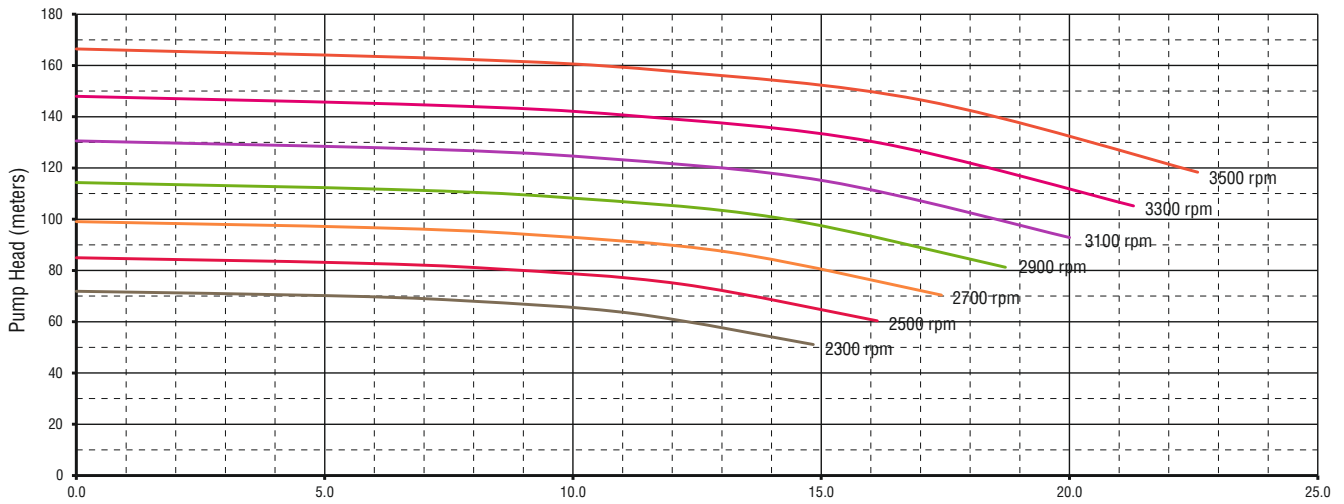

**INDRA HYDRO TECH PUMPS PVT LTD**

No.85/M, Ground Floor, Industrial Suburb, 2nd Stage Gautham Nagar, Tumkur Road

Yeshwanthpur, Bangalore 560 022, Karnataka, INDIA

Tel. : +91 80 4163 5638, Mobile: +91 94835 26899 / 80736 22800

Email : sales@ihpumps.in, Web : www.ihpindia.in | www.ihpumps.in

ISO 60X40-250 PUMP ASSEMBLY WITH BEARING HOUSING 513

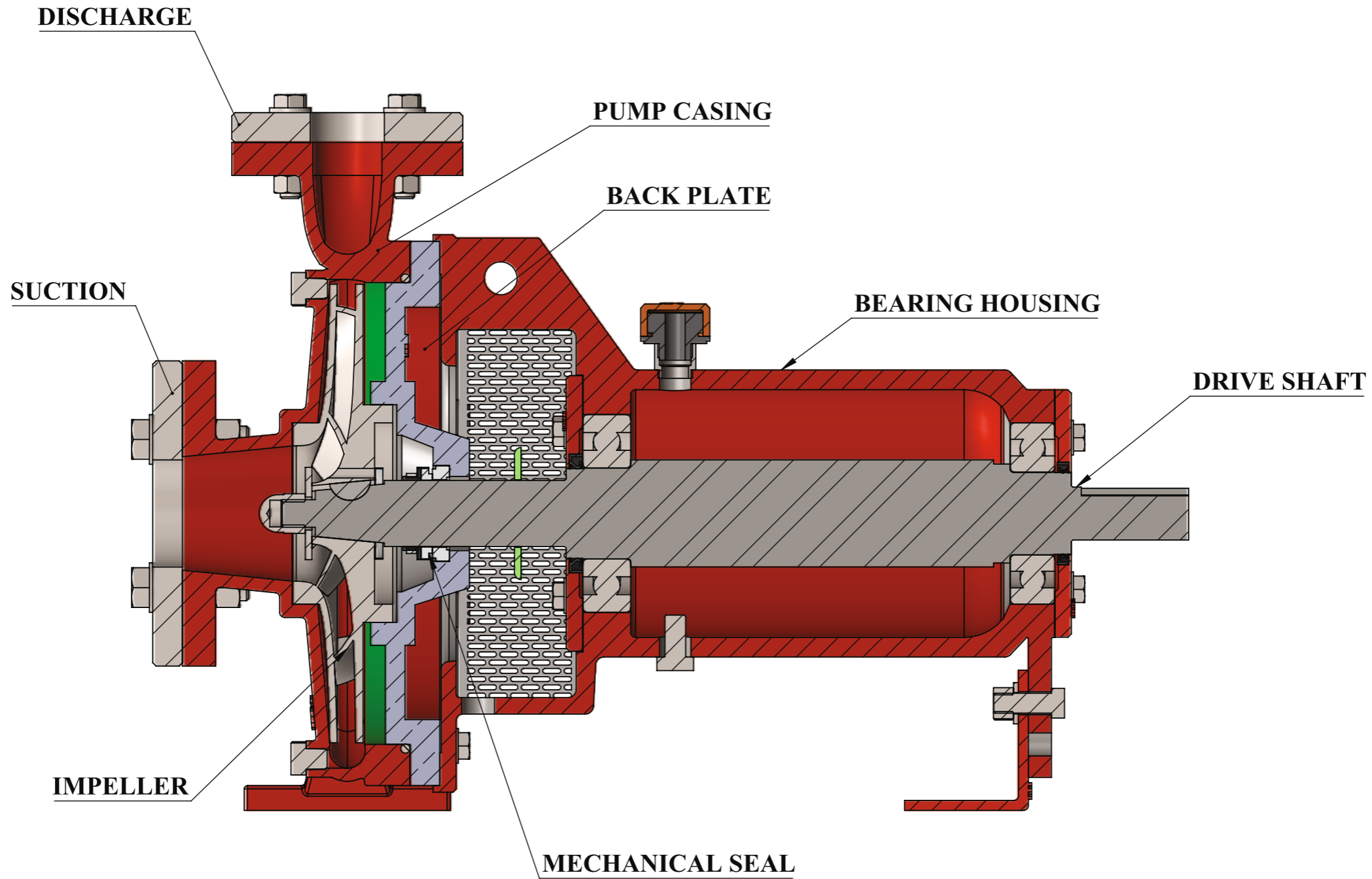

UNLESS OTHERWISE SPECIFIED: DIMENSIONS ARE IN MILLIMETERS SURFACE FINISH: TOLERANCES: LINEAR: ANGULAR:			FINISH:	DEBURR AND BREAK SHARP EDGES	DO NOT SCALE DRAWING	REVISION
					INDRA HYDRO TECH PUMPS PVT.LTD. Bangalore,INDIA	<b>IHP</b> <small>INDRA HYDRO TECH PUMPS PVT. LTD.</small>
DRAWN	NAME	SIGNATURE	DATE	TITLE:		
CHK'D	RAHUL K.S.		06/01/2021	513 BARE SHAFT SINGLE STAGE CENTIFUGAL PUMP		
APPV'D	ARVIND		07/01/2021	DWG NO.		
MFG				513		
Q.A				A3		
				THIRD ANGLE PROJECTION	SCALE:1:10	
				MATERIAL:	SHEET 1 OF 2	
				SGI500/7		
				WEIGHT:		

# ISO 60X40-250 PUMP ASSEMBLY WITH BEARING HOUSING 513

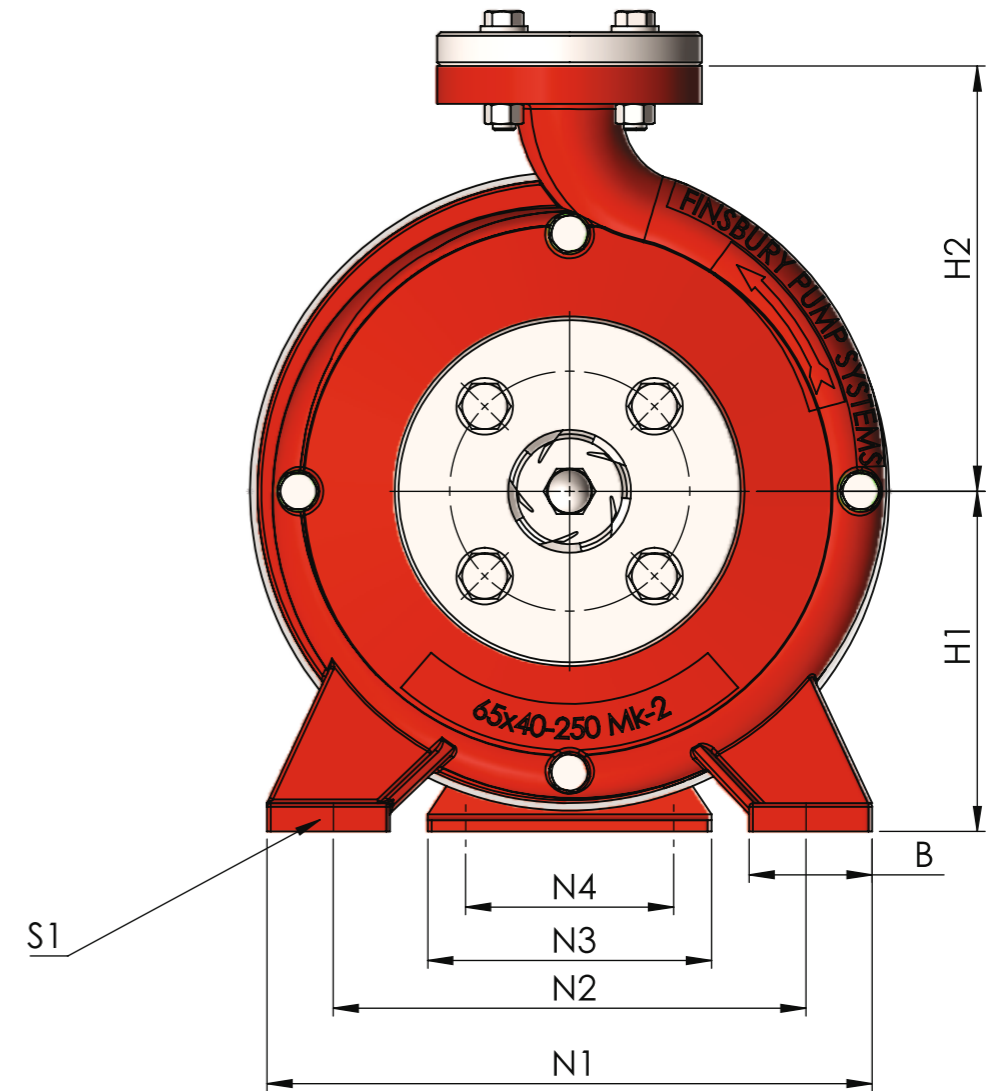
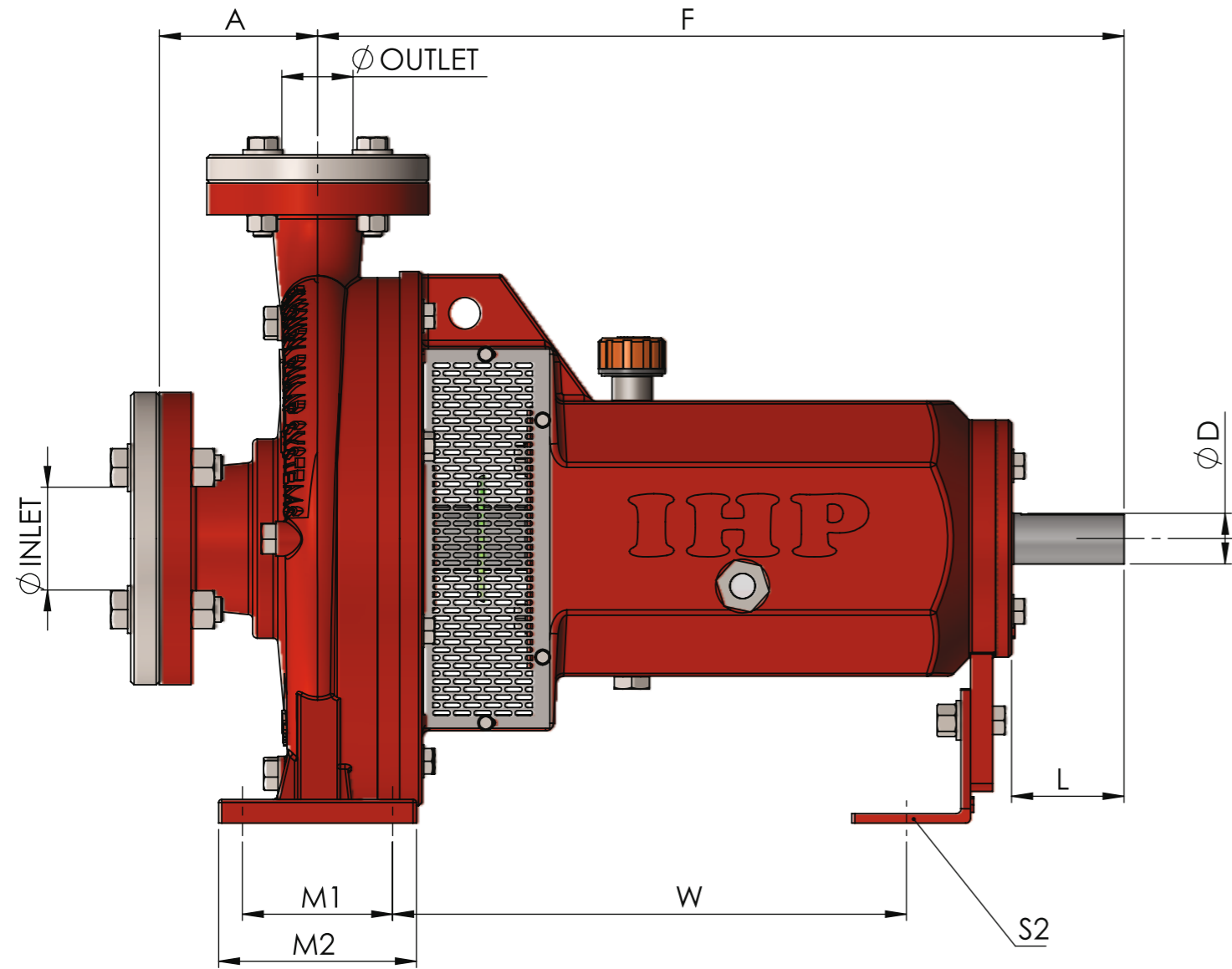

Inlet size: 60mm  
 Outlet size: 40mm  
 Impeller size: 222 to 78mm  
 278mm is standard

Pump:  
 A 100mm  
 F 510mm  
 H1 180mm  
 H2 228mm

Bolt holes:  
 S1 M12  
 S2 M12

Mounting:  
 B 65mm  
 M1 95mm  
 M2 125mm  
 N1 320mm  
 N2 250mm  
 N3 150mm  
 N4 110mm  
 W 325mm

Shaft end:  
 D 32mm  
 L 70mm

Note: These are ISO 2858 standard bare shaft centrifugal pump dimensions.

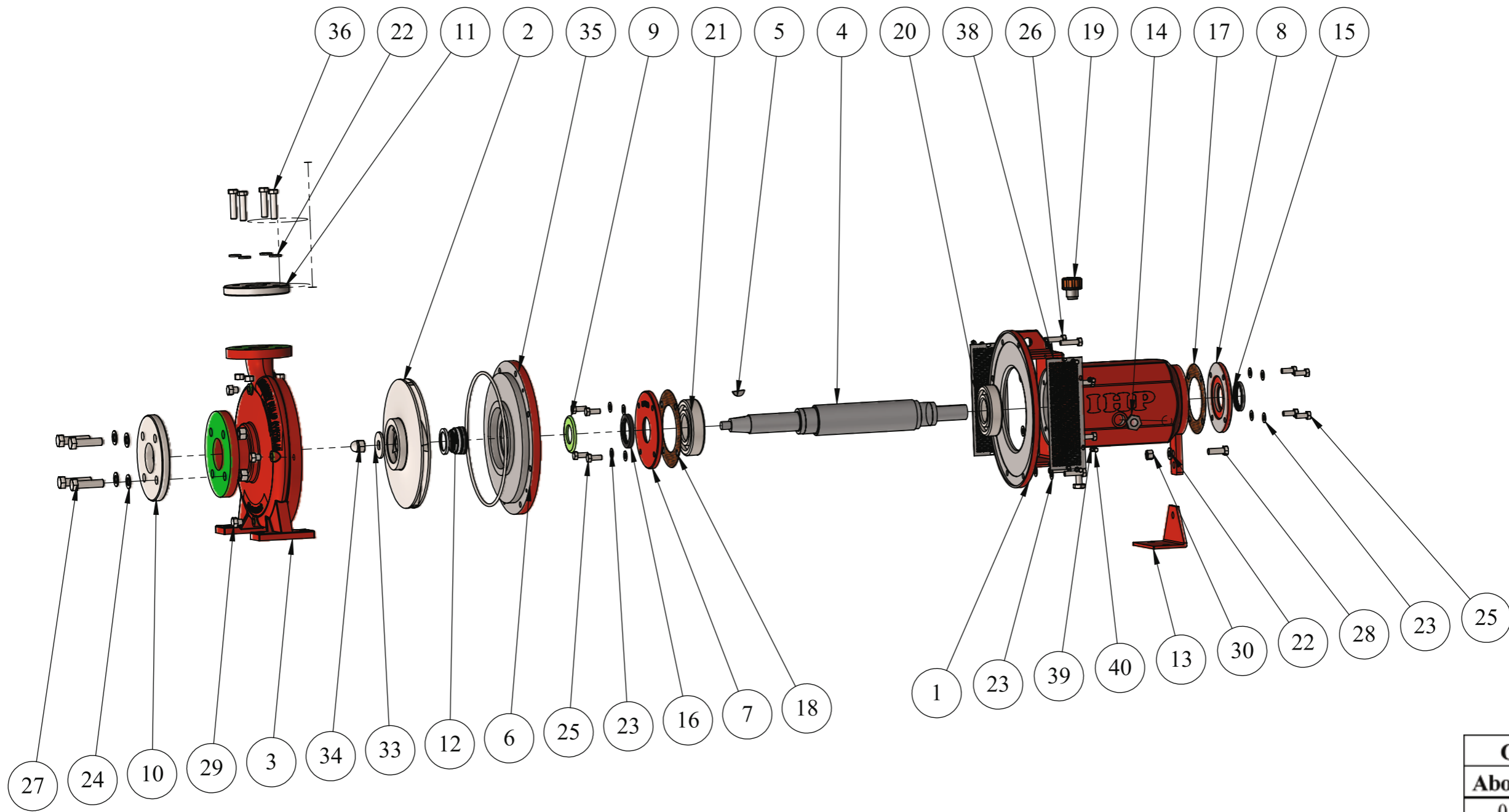

Genl. Tolerance		
Above	Upto	Tol
0	6	±0.1
6	30	±0.2
30	120	±0.3
120	315	±0.5
315	1000	±0.8
1000	2000	±1.2

UNLESS OTHERWISE SPECIFIED:  
 DIMENSIONS ARE IN MILLIMETERS  
 SURFACE FINISH:  
 TOLERANCES:  
 LINEAR:  
 ANGULAR:

FINISH:

DEBURR AND BREAK SHARP EDGES

DO NOT SCALE DRAWING

REVISION

INDRA HYDRO TECH PUMPS PVT.LTD.  
 Bangalore,INDIA

**IHP**  
INDRA HYDRO TECH PUMPS PVT. LTD.

TITLE:  
**ISO 60x40-250 pump assembly  
 with Bearing Housing 513**

NAME	SIGNATURE	DATE
DRAWN RAHUL K.S.		06/01/2021
CHK'D ARVIND		07/01/2021
APPV'D ARVIND		07/01/2021
MFG		
Q.A		

THIRD ANGLE PROJECTION

MATERIAL:  
**SGI500/7**

WEIGHT:

DWG NO.  
**513**

A3

SCALE:1:50

SHEET 1 OF 2

ITEM NO.	PART NUMBER	DESCRIPTION	MATERIAL	QTY.
1	00052A	BEARING HOUSING	SGI500/7	1
2	113 65x40-250	Impeller	SS316	1
3	013 65x40-250	Pump casing	SGI500/7	1
4	309	Shaft	SS431	1
5	808	WOODRUFF KEY	SS316	1
6	00057	BACK PLATE	SGI500/7	1
7	00340	FRONT PLATE FOR BEARING HOUSING	SGI500/7	1
8	00337	END PLATE FOR BEARING HOUSING	SGI500/7	1
9	508	SLINGER	NYLON	1
10	504-1	FLANGE	MS	1
11	508-1	FLANGE	MS	1
12	D40	40mm Mechanical Seal	Silicon	1
13	00391	L Feet	MS	1
14	SG-3/4"	SIGHT GLASS		1
15	P00929	49*62*7mm Oil Seal	VITON	1
16	P09408	54*72*8 Oil Seal	VITON	1
17	337A	PAPER GASKET FOR PLATE 337	GASKET PAPER	1
18	340A	PAPER GASKET FOR PLATE 340	GASKET PAPER	1
19	BC-1/2"	Breather cup		1
20	6310	REAR BEARING		1
21	6311	FRONT BEARING		1
22	FW12	M12 WASHER	ZINC BLUE	5
23	FW10	M10 WASHER	ZINC BLUE	16
24	FW16	M16 WASHER	ZINC BLUE	4
25	BHH10 x 25-NN	HEX HEAD BOLT M10*25MM	ZINC BLUE	8
26	BHH12 x 35-NN	HEX HEAD BOLT M12*35MM	ZINC BLUE	1
27	BHH10 x 40-NN	HEX HEAD BOLT M10*40MM	ZINC BLUE	8
28	BHH16 x 60-NN	HEX HEAD BOLT M16*60MM	ZINC BLUE	4
29	BHH1/4"	DRAIN PLUG	ZINC BLUE	4
30	M12-N	M12 NUT	ZINC BLUE	1
31	M16 - N	M16 NUT	ZINC BLUE	4
32	BHH1/2"	OIL DRAIN PLUG	ZINC BLUE	1
33	FW16	IMPELLER WASHER	SS304	1
34	DM16	IMPELLER DOMED NUT	SS304	1
35	BS379	CASING O-RING (278.77*5.53mm)	NBR	1
36	BHH12 x 55-NN	HEX HEAD BOLT M12*55MM	ZINC BLUE	4
38	M-52A	BEARING HOUSING MESH 52A	SS304	2
39	FW5	FLAT WAHER M5	ZINC BLUE	8
40	BHH5*10	HEX HEAD M5*10mm	ZINC BLUE	8

UNLESS OTHERWISE SPECIFIED: DIMENSIONS ARE IN MILLIMETERS SURFACE FINISH: TOLERANCES: LINEAR: ANGULAR:		FINISH:	DEBURR AND BREAK SHARP EDGES	DO NOT SCALE DRAWING	REVISION
				INDRA HYDRO TECH PUMPS PVT.LTD. Bangalore,INDIA	
NAME	SIGNATURE	DATE	TITLE:		
DRAWN RAHUL K.S.		06/01/2021	ISO 60x40-250 pump assembly with Bearing Housing 513		
CHK'D ARVIND		07/01/2021			
APPV'D ARVIND		07/01/2021			
MFG					
Q.A			MATERIAL:	DWG NO.	A4
			SGI500/7	513	
			WEIGHT:	SCALE:1:50	SHEET 2 OF 2

**INDRA HYDRO TECH PUMPS PVT LTD**

No.85/M, Ground Floor, Industrial Suburb, 2nd Stage Gautham Nagar, Tumkur Road  
Yeshwanthpur, Bangalore 560 022, Karnataka, INDIA

Tel. : +91 80 4163 5638, Mobile: +91 94835 26899 / 80736 22800

Email : sales@ihpumps.in, Web : www.ihpindia.in | www.ihpumps.in