

Finsbury - Bare Shaft Pumps

250 Series



Standard

160 Series bare shaft single stage centrifugal pumps are designed manufactured to ISO Standard 2858

Sl.	Model Number	Max. Shaft Power	Max. Speed RPM	Max. Head Mtr.	Max. Flow LPS
1	FPS-65 x 40-250	60.0Kw	3500	166.0	22.6
2	FPS-80 x 50-250	97.0Kw	3500	164.0	38.7
3	FPS-100 x 65-250	74.0Kw	3500	110.0	48.9
4	FPS-125x100-250	103.0Kw	3500	108.0	94.0
5	FPS-150x125-250	88.0Kw	3500	78.0	94.0

Maximum ambient temperature +60°C
 Maximum fluent temperature +80°C
 Maximum casing pressure 16 bar
 Fluid must be clean free from abrasive particles
 Wear rings - bronze wear rings can be fitted to impeller and casing

Standard MOC
 Casing-SG 500/7
 Impeller-SS316-Bronze
 Shaft-Stainless Steel 431 with water slinger
 Bearing-Fully Sealed heavy duty roller bearing

INDRA HYDRO TECH PUMPS PVT LTD

No.85/M, Ground Floor, Industrial Suburb, 2nd Stage Gautham Nagar, Tumkur Road
 Yeshwanthpur, Bangalore 560 022, Karnataka, INDIA

Tel. : +91 80 4163 5638, Mobile: +91 94835 26899 / 80736 22800

Email : sales@ihpumps.in, Web : www.ihpindia.in | www.ihpumps.in

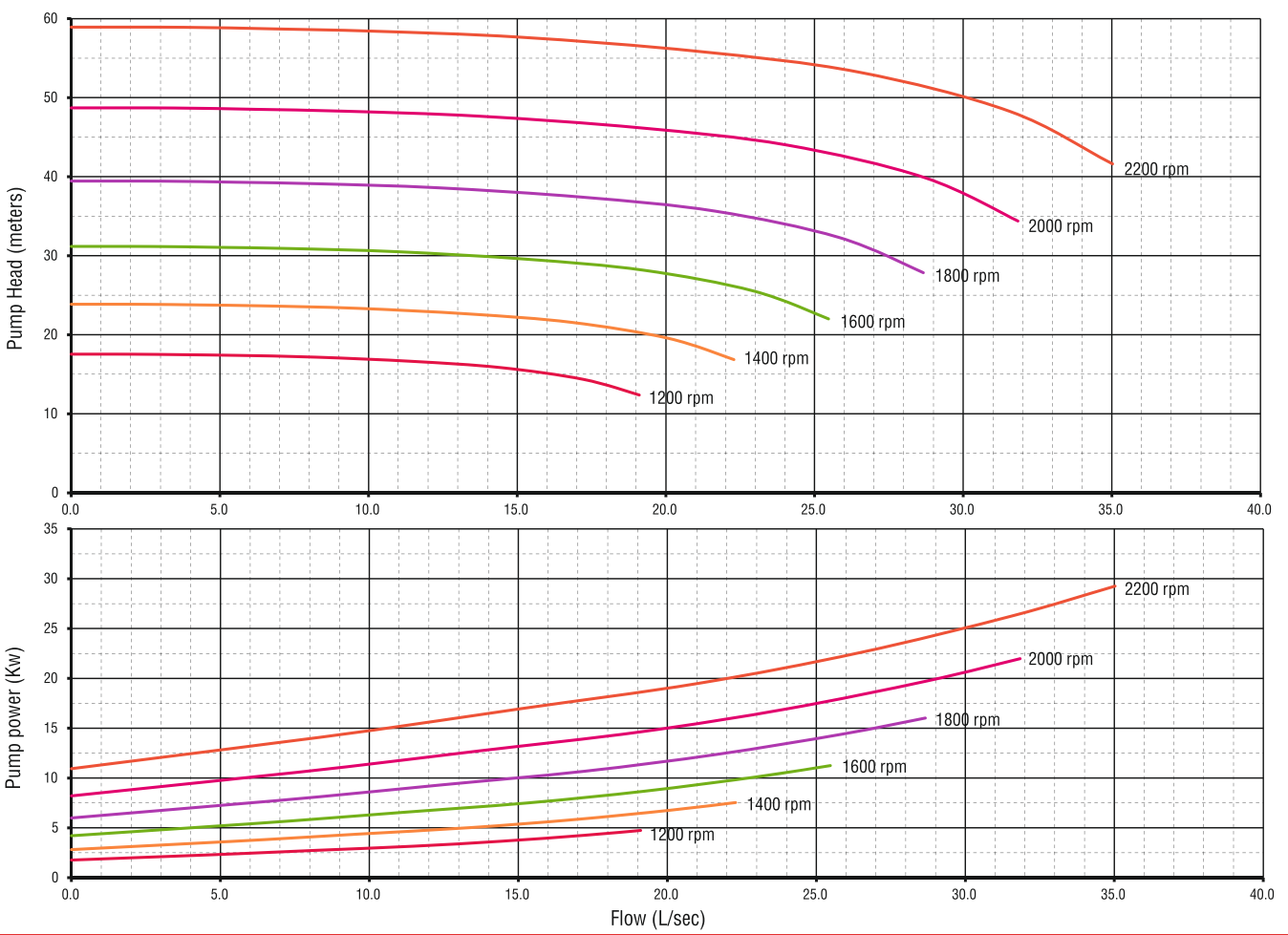
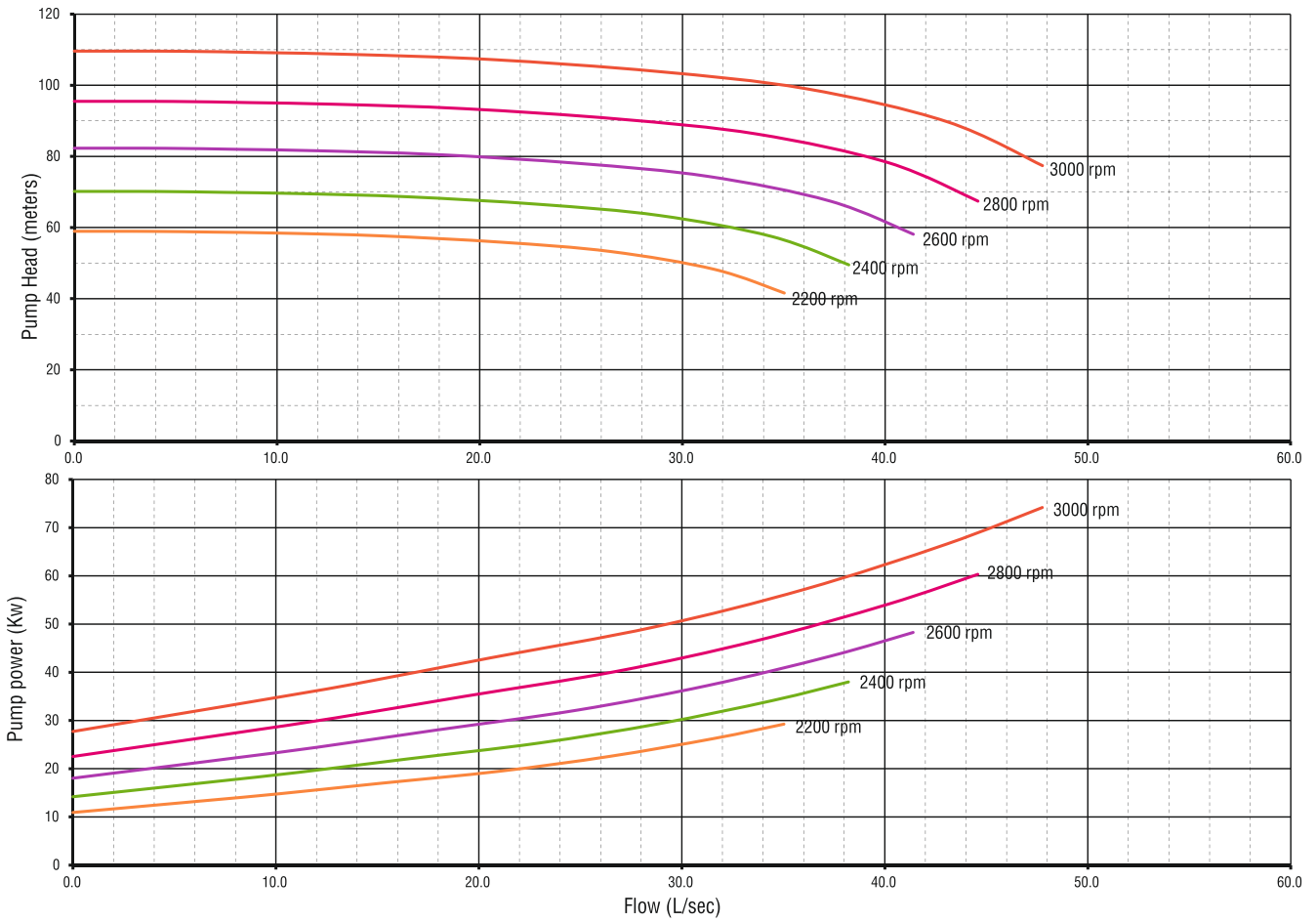

INDRA HYDRO TECH PUMPS PVT LTD

No.85/M, Ground Floor, Industrial Suburb, 2nd Stage Gautham Nagar, Tumkur Road
Yeshwanthpur, Bangalore 560 022, Karnataka, INDIA
Tel. : +91 80 4163 5638, Mobile: +91 94835 26899 / 80736 22800
Email : sales@ihpumps.in, Web : www.ihpindia.in | www.ihpumps.in

ISO 100X65-250 PUMP ASSEMBLY WITH BEARING HOUSING 515

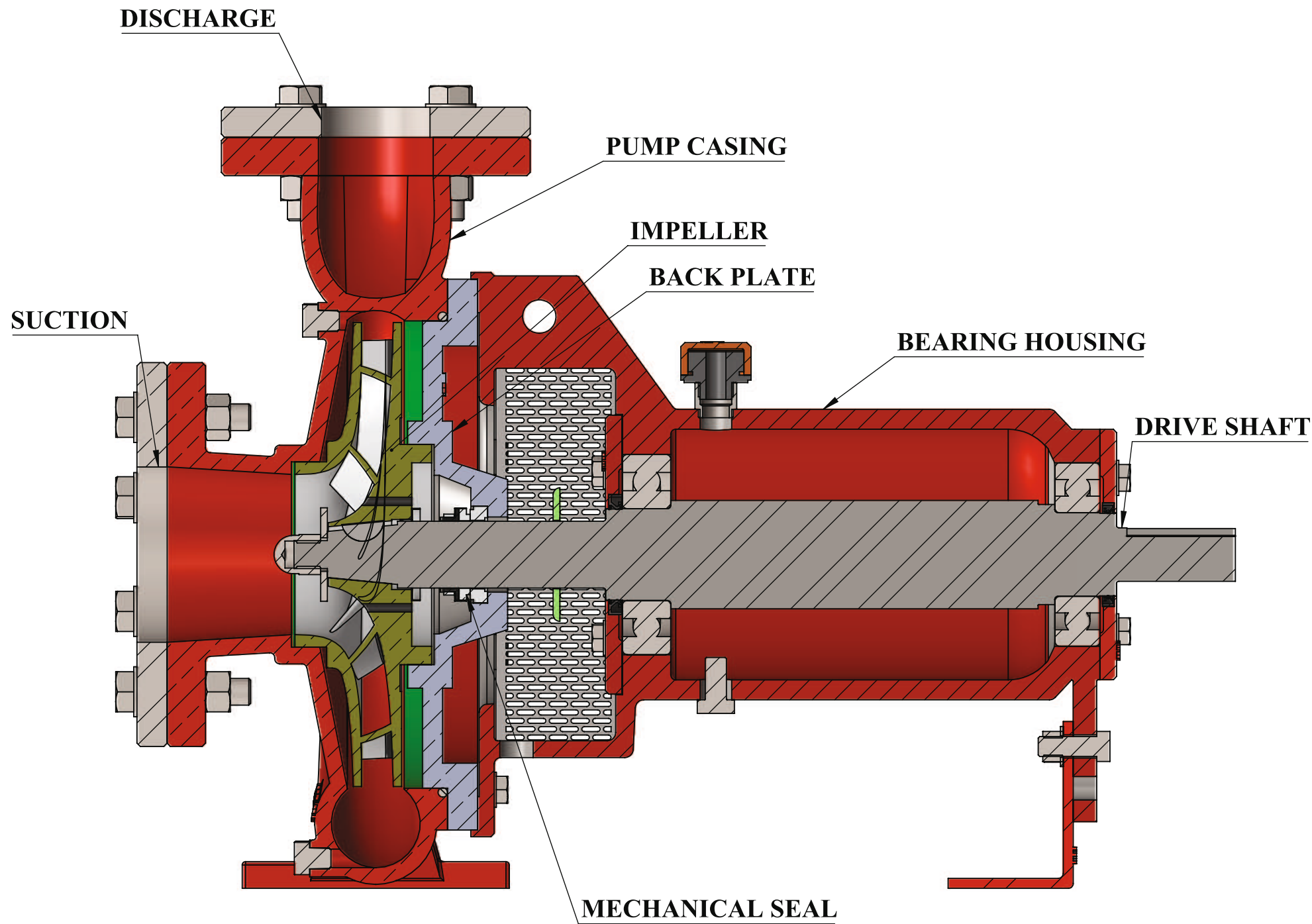

UNLESS OTHERWISE SPECIFIED: DIMENSIONS ARE IN MILLIMETERS SURFACE FINISH: TOLERANCES: LINEAR: ANGULAR:			FINISH:	DEBURR AND BREAK SHARP EDGES	DO NOT SCALE DRAWING	REVISION
DRAWN RAHUL K.S.			SIGNATURE	DATE	INDRA HYDRO TECH PUMPS PVT.LTD. Bangalore,INDIA	IHP <small>INDRA HYDRO TECH PUMPS PVT.LTD.</small>
CHK'D ARVIND		07/01/2021			TITLE: 515 BARE SHAFT SINGLE STAGE CENTIFUGAL PUMP	
APPV'D ARVIND		07/01/2021			DWG NO.	515
MFG						A3
Q.A					SCALE:1:10	SHEET 1 OF 2
				THIRD ANGLE PROJECTION		
				MATERIAL: SGI500/7		
				WEIGHT:		

ISO 100X65-250 PUMP ASSEMBLY WITH BEARING HOUSING 515

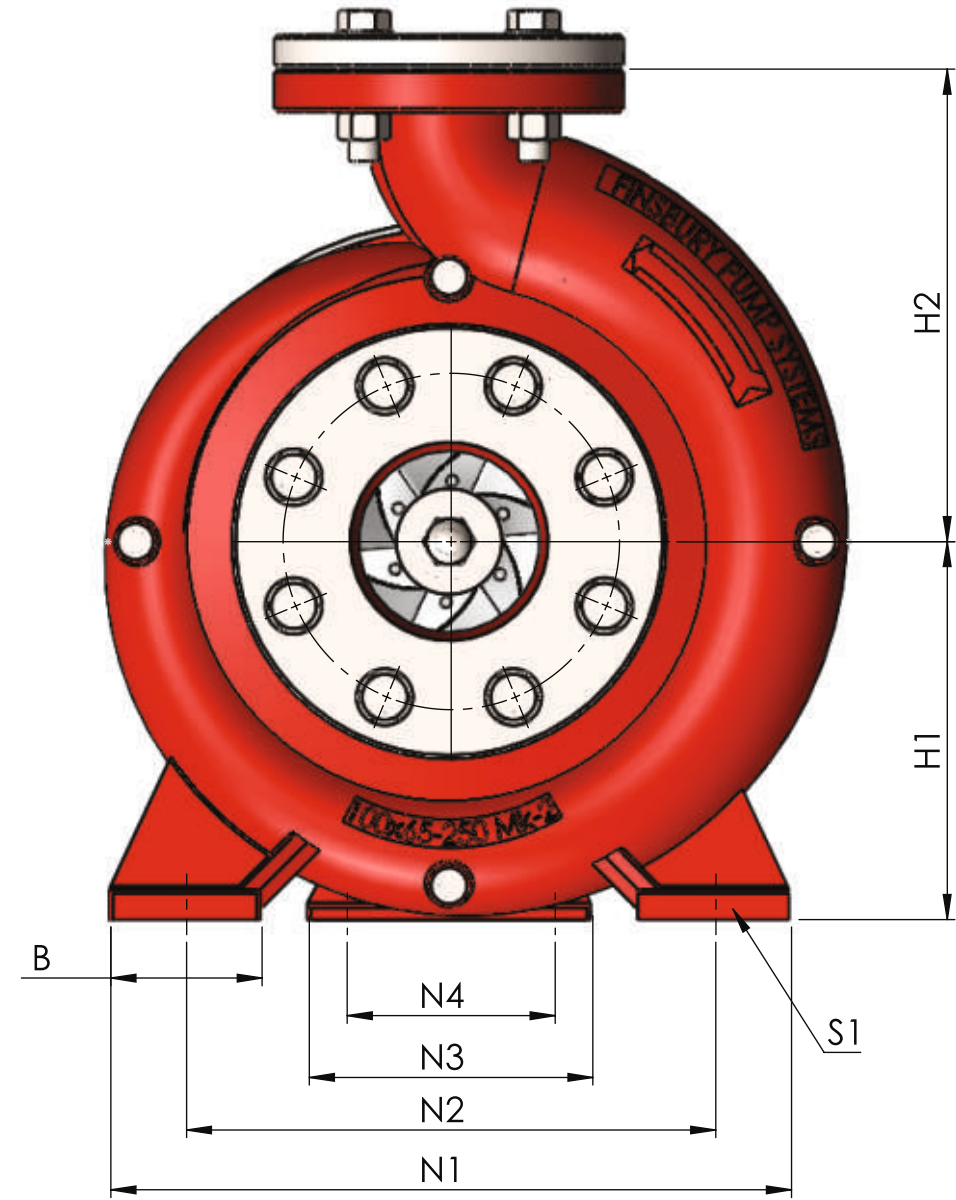
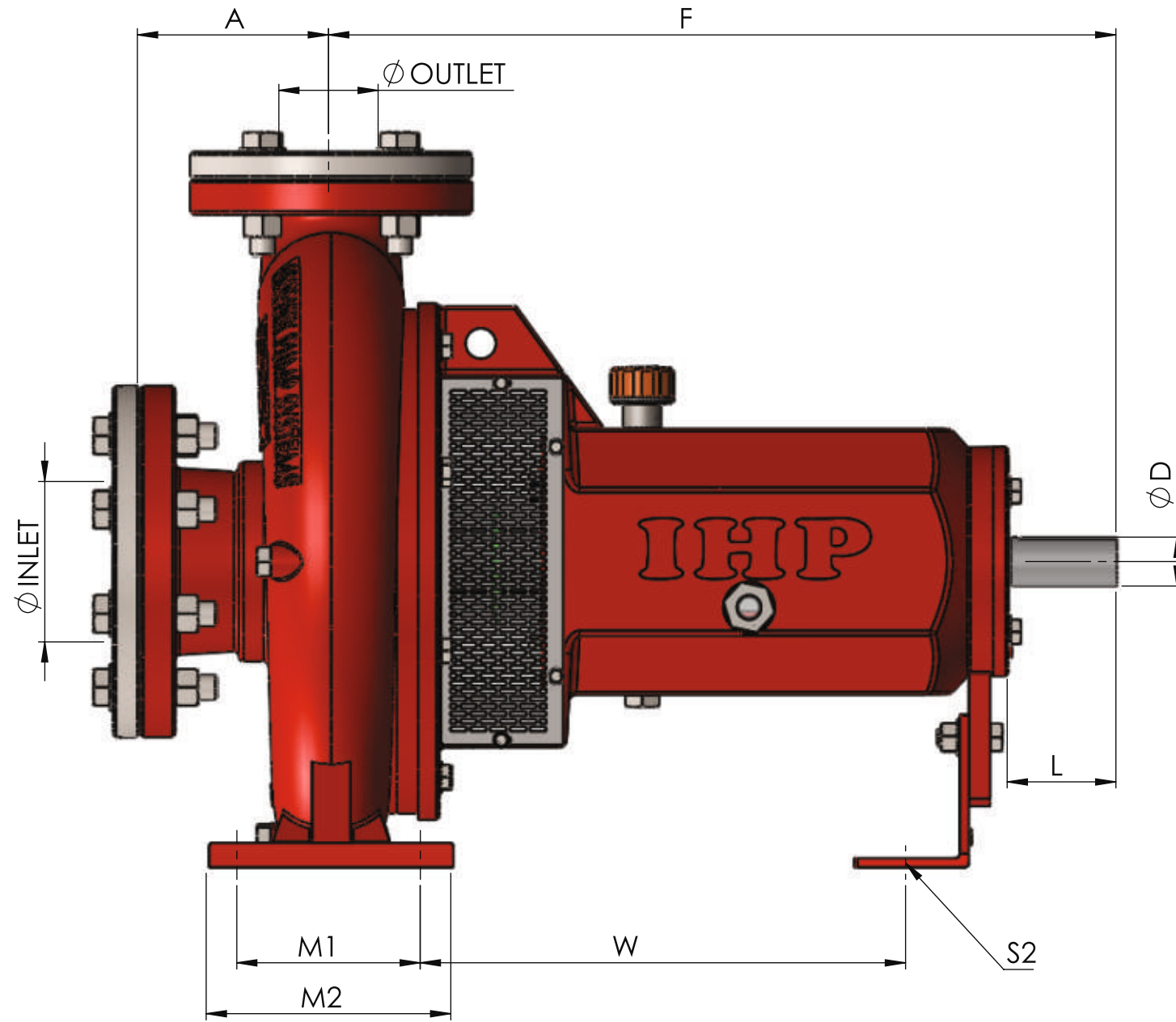

Inlet size: 100mm
 Outlet size: 65mm
 Impeller size: 222 to 78mm
 278mm is standard

Pump: A 125mm
 F 515mm
 H1 200mm
 H2 250mm

Bolt holes: S1 M12
 S2 M12

Note: These are ISO 2858 standard bare shaft centrifugal pump dimensions.

Mounting: B 80mm
 M1 120mm
 M2 160mm
 N1 360mm
 N2 280mm
 N3 150mm
 N4 110mm
 W 317.5mm

Shaft end: D 32mm
 L 70mm

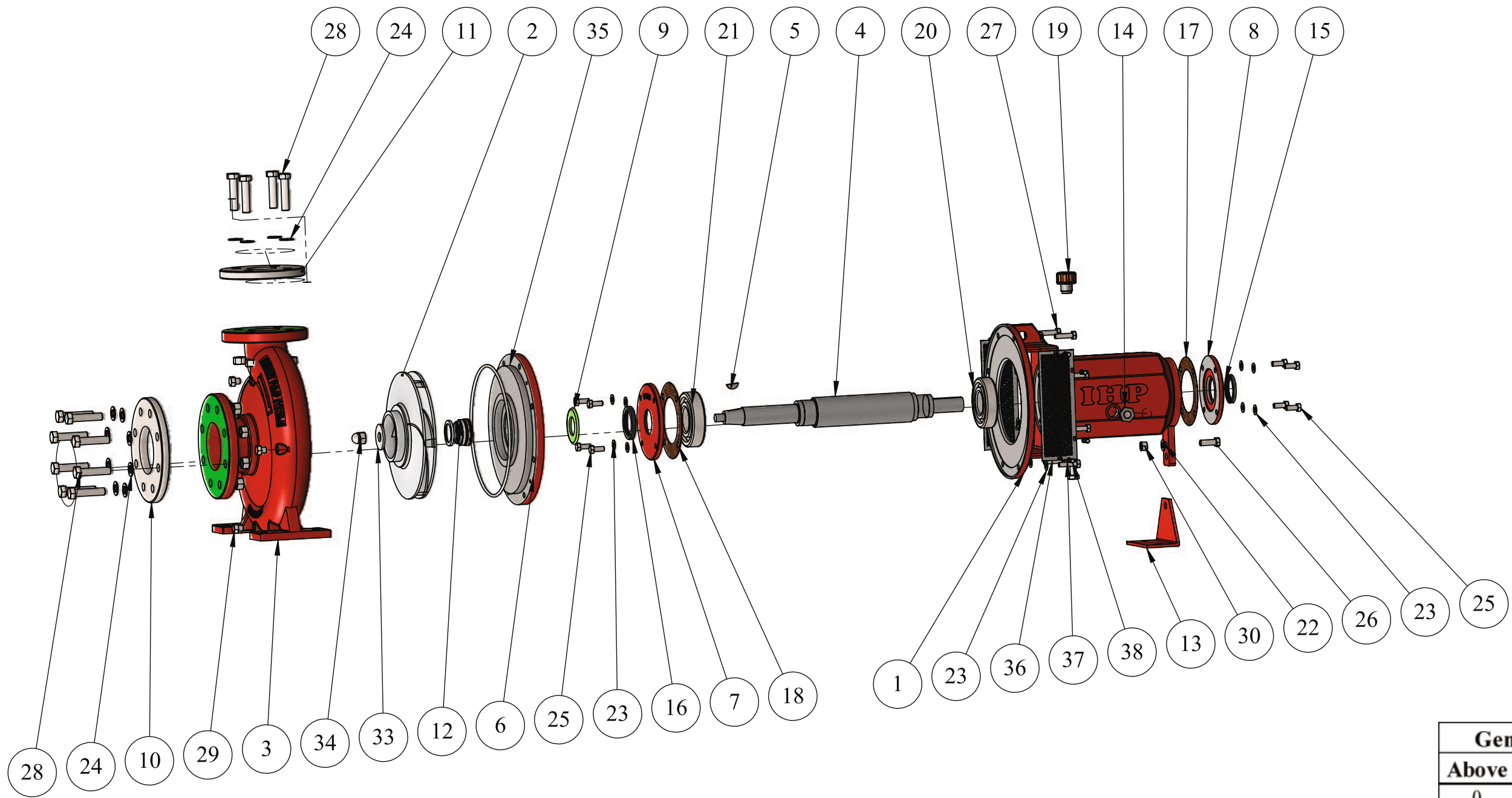

Genl. Tolerance		
Above	Upto	Tol
0	6	±0.1
6	30	±0.2
30	120	±0.3
120	315	±0.5
315	1000	±0.8
1000	2000	±1.2

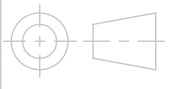
UNLESS OTHERWISE SPECIFIED: DIMENSIONS ARE IN MILLIMETERS SURFACE FINISH: TOLERANCES: LINEAR: ANGULAR:			FINISH:	DEBURR AND BREAK SHARP EDGES	DO NOT SCALE DRAWING	REVISION	
DRAWN RAHUL K.S.			SIGNATURE	DATE	INDRA HYDRO TECH PUMPS PVT.LTD. Bangalore,INDIA		
CHK'D ARVIND				07/01/2021	 ISO 100x65-250 pump assembly with Bearing Housing 515		
APPV'D ARVIND				07/01/2021			
MFG			 THIRD ANGLE PROJECTION			TITLE:	
Q.A						MATERIAL:	
			SGI500/7			515	A3
			WEIGHT:			SCALE:1:50	SHEET 1 OF 2

ITEM NO.	PART NUMBER	DESCRIPTION	MATERIAL	QTY.
1	00052A	BEARING HOUSING	SGI500/7	1
2	115 100x65-250	Impeller	SS316	1
3	015 100x65-250	Pump casing	SGI500/7	1
4	311	Shaft	SS431	1
5	808	WOODRUFF KEY	SS316	1
6	00057	BACK PLATE	SGI500/7	1
7	00340	FRONT PLATE FOR BEARING HOUSING	SGI500/7	1
8	00337	END PLATE FOR BEARING HOUSING	SGI500/7	1
9	508	SLINGER	NYLON	1
10	505-2	FLANGE	MS	1
11	503-2	FLANGE	MS	1
12	D40	40mm Mechanical Seal	Silicon	1
13	00392	L Feet	MS	1
14	SG-3/4"	SIGHT GLASS		1
15	P0929	49*62*7mm Oil Seal	VITON	1
16	P09408	54*72*8 Oil Seal	VITON	1
17	337A	PAPER GASKET FOR PLATE 337	GASKET PAPER	1
18	340A	PAPER GASKET FOR PLATE 340	GASKET PAPER	1
19	BC-1/2"	Breather cup		1
20	6310	REAR BEARING		1
21	6311	FRONT BEARING		1
22	FW12	M12 WASHER	ZINC BLUE	1
23	FW10	M10 WASHER	ZINC BLUE	16
24	FW16	M16 WASHER	ZINC BLUE	12
25	BHH10 x 25-NN	HEX HEAD BOLT M10*25MM	ZINC BLUE	8
26	BHH12 x 35-NN	HEX HEAD BOLT M12*35MM	ZINC BLUE	1
27	BHH10 x 40-NN	HEX HEAD BOLT M10*40MM	ZINC BLUE	8
28	BHH16 x 70-NN	HEX HEAD BOLT M16*70MM	ZINC BLUE	12
29	BHH1/4"	DRAIN PLUG	ZINC BLUE	4
30	M12-N	M12 NUT	ZINC BLUE	1
31	M16 - N	M16 NUT	ZINC BLUE	12
32	BHH1/2"	OIL DRAIN PLUG	ZINC BLUE	1
33	FW16	IMPELLER WASHER	SS304	1
34	DM16	IMPELLER DOMED NUT	SS304	1
35	BS379	CASING O-RING (278.77*.5.53mm)	NBR	1
36	M-52A	BEARING HOUSING MESH 52A	SS304	2
37	FW5	M5 WASHER	ZINC BLUE	8
38	BHH5 x 10-NN	HEX HEAD BOLT M5*10MM	ZINC BLUE	8

UNLESS OTHERWISE SPECIFIED:
DIMENSIONS ARE IN MILLIMETERS
SURFACE FINISH:
TOLERANCES:
LINEAR:
ANGULAR:

FINISH:

DEBURR AND
BREAK SHARP
EDGES

DO NOT SCALE DRAWING

REVISION

INDRA HYDRO TECH PUMPS PVT.LTD.
Bangalore,INDIA



	NAME	SIGNATURE	DATE
DRAWN	RAHUL K.S.		06/01/2021
CHKD	ARVIND		07/01/2021
APPV'D	ARVIND		07/01/2021
MFG			
Q.A			

TITLE:

ISO 100x65-250 pump assembly
with Bearing Housing 515

MATERIAL:

SGI500/7

DWG NO.

515

A4

WEIGHT:

SCALE:1:50

SHEET 2 OF 2

INDRA HYDRO TECH PUMPS PVT LTD

No.85/M, Ground Floor, Industrial Suburb, 2nd Stage Gautham Nagar, Tumkur Road
Yeshwanthpur, Bangalore 560 022, Karnataka, INDIA

Tel. : +91 80 4163 5638, Mobile: +91 94835 26899 / 80736 22800

Email : sales@ihpumps.in, Web : www.ihpindia.in | www.ihpumps.in